

2

1

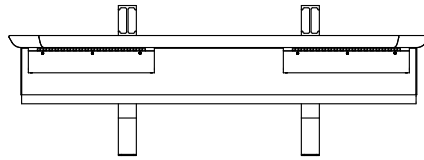

CHAIN HANGERS WITH 12 HANGERS EACH

1/8 ALU CHECKER PANEL

FULL CHAIN BUCKET

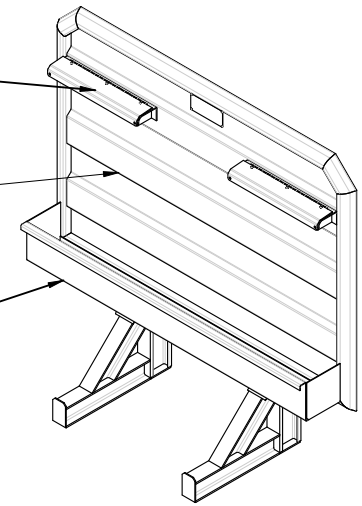

TREBOR NAME PLATE APPROX. LOCATION

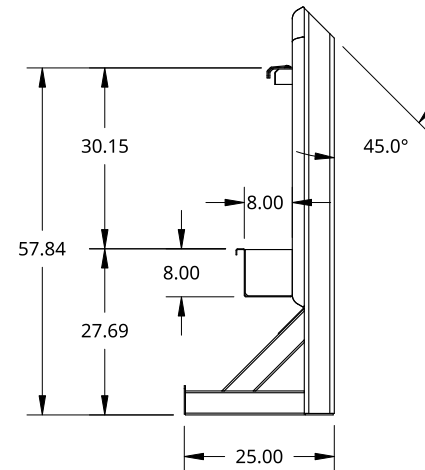
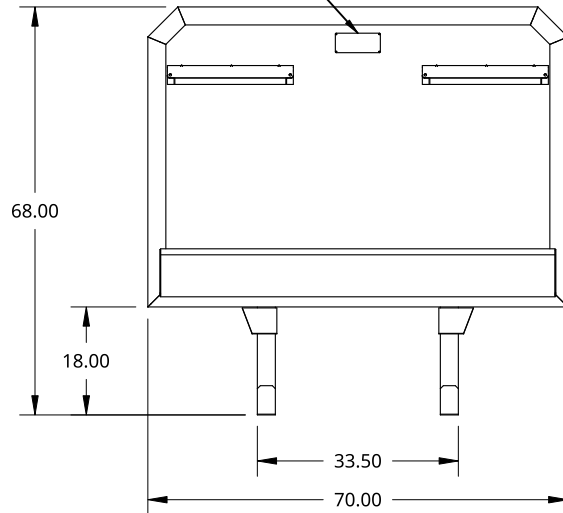



B

B

A

A

<small>THIS DOCUMENT IS THE PROPERTY OF TREBOR MANUFACTURING. ANY UNAUTHORIZED REPRODUCTION WILL BE PROSECUTED TO THE FULL EXTENT OF THE LAW</small>				PART NO. <b>TR6870-PLUS</b>	REV. <b>C</b>
<small>UNLESS OTHERWISE SPECIFIED, DIMENSIONS ARE IN INCHES          .XX = ±.1-          .XXX = ±.015-          .XXXX = ±.005-          ANGULAR = ±1°          FRACTIONAL = ±1/8</small>		DRAWN SHAWN CROCKER 08/24/2021		STANDARD CAB SHIELD - 68 X 70 - 1/8 ALU CHECKER PANEL - CHAIN HANGER AND BUCKET	
THIRD ANGLE PROJECTION 		MATERIAL <b>ALUMINUM</b>		SIZE <b>A</b>	DWG NO. <b>D5649</b>
		SCALE <b>1:32</b>	WEIGHT <b>160.29 LB</b>	SHEET <b>1 of 1</b>	REV. <b>B</b>

2

1