

2

1

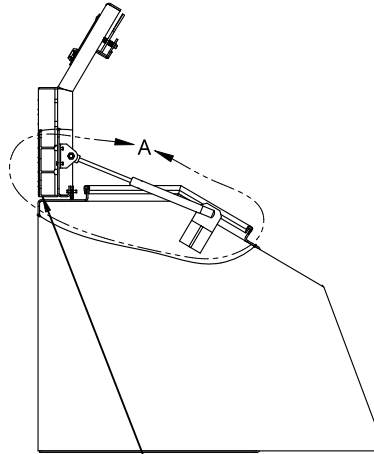

FLUSH WITH BACK OF
BOX WHEN OPEN TO
90 DEG

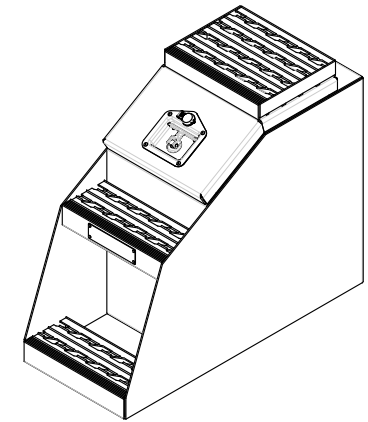
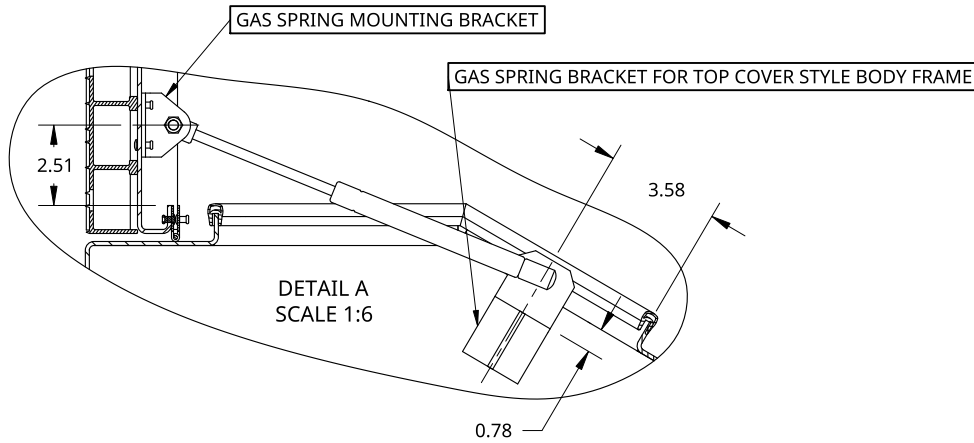
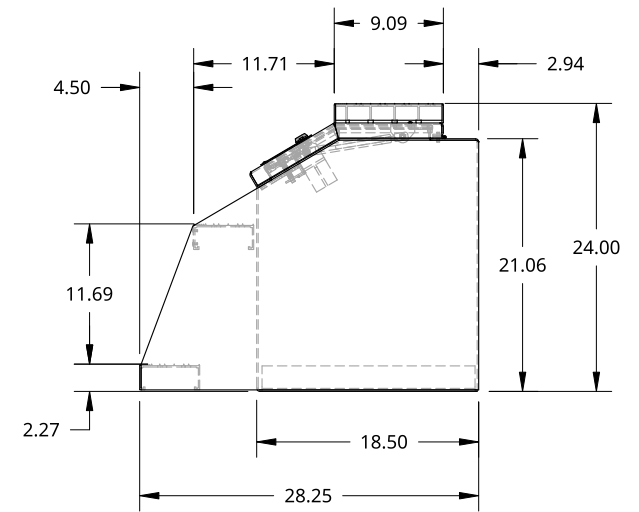
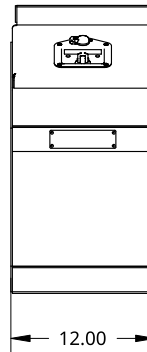

RELEASED

REVISIONS			
REVISION	REVISION DESCRIPTION	DATE APPROVED	APPROVER
A	RELEASED TO MFG	07/16/2021	SHAWN CROCKER
B	PART NUMBERED ALL PARTS	11/17/2022	SHAWN CROCKER

THIS DOCUMENT IS THE PROPERTY OF TREBOR
MANUFACTURING. ANY UNAUTHORIZED REPRODUCTION
WILL BE PROSECUTED TO THE FULL EXTENT OF THE LAW

UNLESS OTHERWISE SPECIFIED,
DIMENSIONS ARE IN INCHES

.XX = ±.1-
.XXX = ±.015-
.XXXX = ±.005-

ANGULAR = ±1°
FRACTIONAL = ±1/8

THIRD ANGLE PROJECTION

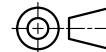

DRAWN BY SHAWN CROCKER 07/15/2021
CHANGED BY SHAWN CROCKER 11/17/2022

MATERIAL
1/8 ALU MILL

PART NO.		TRSTBPLBM12		REV.	B
BIG MOUTH STEP BOX - 28.25 X 24 X 12 - X1 T-HANDLE - 9IN TOP STEP					
SIZE	A	DWG NO.	D8032		REV.
SCALE	1:16	WEIGHT	34.06 LB	SHEET	1 of 1

2

1

B

B

A

A